

USER'S MANUAL  
ENERGY STORAGE INVERTER

# USER'S MANUAL ENERGY STORAGE INVERTER

9KW-12KW



Appliances



PC



TV



Air-  
conditioning



Fridge



Washing  
machine

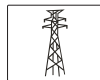

Grid

# Table Of Contents

<b>ABOUT THIS MANUAL</b> .....	1
<b>SAFETY INSTRUCTIONS</b> .....	1
<b>INSTALLATION</b> .....	2
Features .....	2
Basic System Architecture .....	2
Product Overview .....	3
Packing List .....	3
User Environment .....	4
Battery Connection .....	4
PV Connection .....	6
GRID/LOAD Connection .....	7
Connecting To The grid .....	8
Communication And BTS Connection .....	9
Communication Connection .....	9
BTS Connection .....	9
<b>OPERATION</b> .....	10
Operation and Display Panel .....	10
LCD Display Icons .....	11
LCD Setting .....	13
Display Setting .....	18
Support three-phase equipment .....	21
Operating State Description .....	22
Fault Reference Code .....	23
Warning Indicator .....	25
<b>SPECIFICATIONS</b> .....	27
Table 1 Line Mode Specifications .....	27
Table 2 Inverter Mode Specifications .....	28
Table 3 Charge Mode Specifications .....	29
Table 4 General Specifications .....	30
<b>TROUBLE SHOOTING</b> .....	31
<b>Appendix: Approximate Back-up Time Table</b> .....	33

## APPENDIX: APPROXIMATE BACK-UP TIME TABLE

Model	Load(W)	Back Time@48Vdc 400 Ah(min)	Back Time@48Vdc 600Ah(min)
9KW	900	1082	1674
	1800	484	811
	2700	311	501
	3600	213	363
	4500	170	273
	5400	142	213
	6300	113	183
	7200	99	149
	8100	88	132
12KW	9000	68	102
	1200	811	1217
	2400	363	563
	3600	213	363
	4800	149	256
	6000	119	192
	7200	85	149
	8400	73	109
	9600	64	96
	10800	56	85
12000	51	76	

**Note:** Backup time depends on the quality of the battery, age of battery and type of battery. Specifications of batteries may vary depending on different manufacturers.



**Power Inverter**  
Líderes en transformaciones de energía

Fault code 80	CAN data loss	1. Check if communication cables are connected well and restart the inverter. 2. If the problem remains, please contact your installer.
Fault code 81	Host data loss	
Fault code 82	Synchronization data loss	
Fault code 83	The battery voltage of each inverter is not the same.	1. Make sure all inverters share same groups of batteries together. 2. If the problem remains, please contact your installer.
Fault code 84	AC input voltage and frequency are detected different	1. Check the grid wiring connection and restart the inverter. 2. If the problem remains, please contact your installer.
Fault code 85	AC output current unbalance	1. Restart the inverter. 2. If the problem remains, please contact your installer.
Fault code 86	AC output mode setting is different	1. Switch off the inverter and check the DIP switch setting. 2. If the problem remains, please contact your installer.
Fault code 87	Current feedback into the inverter is detected.	1. Restart the inverter. 2. If the problem remains, please contact your installer.
Fault code 88	The firmware version of each inverter is not the same.	1. Update all inverter firmware to the same version. 2. If the problem remains, please contact your installer.
Fault code 89	The output current of each inverter is different.	1. Check if sharing cables are connected well and restart the inverter. 2. If the problem remains, please contact your installer.
Fault code 90	CAN ID setting Error	1. Switch off the inverter and check the DIP switch setting. 2. If the problem remains, please contact your installer.

## ABOUT THIS MANUAL

### Purpose

This manual describes the assembly, installation and troubleshooting of this unit. Please read this manual carefully before installations and operations. Keep this manual for future reference.

### Scope

This manual provides safety and installation guidelines as well as information on tool and wiring.

## SAFETY INSTRUCTIONS

- Before using the inverter, please read all instructions and cautionary markings on the unit and this manual. Store the manual where it can be accessed easily.
- **CAUTION** -To reduce risk of injury, charge only deep-cycle lead acid type rechargeable batteries. Other types of batteries may burst, causing personal injury and damage.
- Do not disassemble the unit. Take it to a qualified service center when service or repair is required. Incorrect re-assembly may result in a risk of electric shock or fire.
- To reduce risk of electric shock, disconnect all wirings before attempting any maintenance or cleaning. Turning off the unit will not reduce this risk.
- **CAUTION**-Only qualified personnel can install this device with battery.
- **NEVER** charge a frozen battery.
- For optimum operation of this energy storage inverter, please follow required spec to select appropriate cable size. It's very important to correctly operate this energy storage inverter.
- Be very cautious when working with metal tools on or around batteries. A potential risk exists to drop a tool to spark or short circuit batteries or other electrical parts and could cause an explosion.
- Please strictly follow installation procedure when you want to disconnect AC or DC terminals, Please refer to INSTALLATION section of this manual for the battery supply.
- Fuse 2 pieces of 200A,58VDC for 9KW,3pieces of 200A,58VDC for 12KW, are provided as over-current protection for the battery supply.
- GROUNDING INSTRUCTIONS-This energy storage inverter should be connected to a permanent grounded wiring system. Be sure to comply with local requirements and regulation to install this inverter.
- NEVER cause AC output and DC input short circuited. Do NOT connect to the mains when DC input short circuits.
- Warning!! Only qualified service persons are able to service this device. If errors still persist after following troubleshooting table, please send this energy storage inverter back to local dealer or service center for maintenance.



## INTRODUCTION

This is a multi-function Energy Storage Inverter, combining functions of inverter, On-Grid, MPPT solar charger and battery charger to offer uninterruptible power support with portable size. Its comprehensive LCD display offers user-configurable and easy-accessible button operation such as battery charging current, AC/solar charger priority, and ascertainable input voltage based on different applications.

## Features

- Pure sine wave inverter
- Built-in MPPT solar charge controller On-grid Inverter with Energy Storage
- Selectable input voltage range for home appliances and personal computers LCD setting
- Selectable battery charging current based on applications via LCD Selectable Multiple application Load priority mode, Math load mode, Sell mode, Backup UPS mode and Off grid priority mode
- Auto restart while AC is recovering
- Smart battery charge design for optimized battery performance
- Multiple communication for RS-485 and CAN bus
- Overload and short circuit protection
- Multiple operations: Grid tie, off grid, and grid-tie with backup
- Unique structure design to ensure good heat dissipation, greatly improved product lifespan

## Basic System Architecture

This energy storage inverter can provide Power to connected loads by utilizing PV power, grid power and battery power.

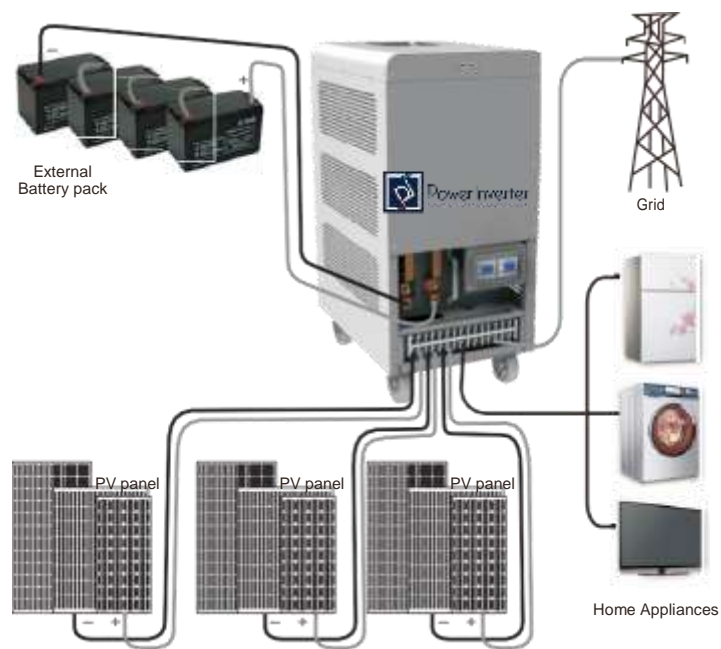

## TROUBLE SHOOTING

Problem	LCD/LED	Explanation / Possible cause	What to do
Unit shuts down automatically during startup process	Fault code 04 No indication.	1. The battery voltage is far too low. (<1.4V/Cell)	1. Re-charge battery. 2. Replace battery.
No response after power on.	(Input voltage is displayed as 0 on the LCD and green LED is flashing)	2. Battery polarity is connected reversed	1. Check if batteries and the wiring are connected well. 2. Re-charge battery. 3. Replace battery
Mains exist but the unit works in battery mode.	Green LED is flashing.	Input protector is tripped.	Check if AC breaker is tripped and AC wiring is connected well.
When the unit is turned on, internal relay is switched on and off repeatedly	LCD display and LEDs are flashing.	Insufficient quality of AC power: (Shore or Generator)	1. Check if AC wires are too thin and/or too long. 2. Check if generator (if applied) is working well or if input voltage range setting is correct. (Appliance -Wide)
		Battery is disconnected.	Check if battery wires are connected well.
		Overload error. The inverter is overload 110% and time is up.	Reduce the connected load by switching off some equipment
	Fault code 07		Check if wiring is connected well and remove abnormal load.
	Fault code 05	Output short circuited.	Check whether the air flow of the unit is blocked or whether the ambient temperature is too high.
	Fault code 02	Internal temperature of inverter component is over 160°C.	
	Fault code 03	Battery is over-charged. The battery voltage is too high.	Return to repair center. Check if spec and quantity of batteries are meet requirements.
	ed LED is on.	<b>Fault code 01</b>	<b>Fan fault</b> <b>Replace the fan.</b>
		Fault code 06/58	Output abnormal (Inverter voltage below than 202 Vac or is higher than 253 vac) 1. Reduce the connected load. 2. Return to repair center
		Fault code 06/09/57	Internal components failed Return to repair center.
		Fault code 51	Over current or surge.
		Fault code 52	Bus voltage is too low.
		Fault code 52	Bus voltage is too low.
		Fault code 55	Output voltage is unbalanced.
		Fault code 55	Output voltage is unbalanced.
		Fault code 56	Battery is not connected well or fuse is burnt. If the battery is connected well, please return to repair center.

Grid		
MAX Charging Current per phase	60A	80A
Default Grid Charging Current per phase	60A	80A
Default Solar Charging Current per phase	60A	60A

Table 4 General Specifications

INVERTER MODEL	9KW	12KW
Safety Certification	CE	
Dimension(W*H*D),mm	391*836*555	
Net Weight,kg	129	145.5
Operating Temperature Range	-25℃ to +55℃	
Storage temperature	-25℃ to +60℃	
Ambient humidity	0 to 90% relative humidity(non-condensing)	
Environmental Protection Rating	IP20	
Altitude	≤3000m	

1.



**Power Inverter**  
Líderes en transformaciones de energía

## Product Overview

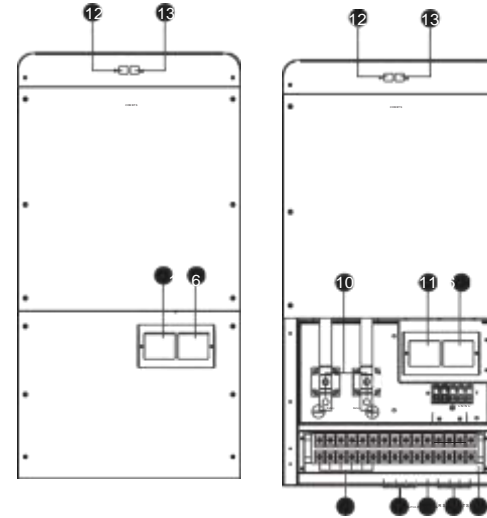
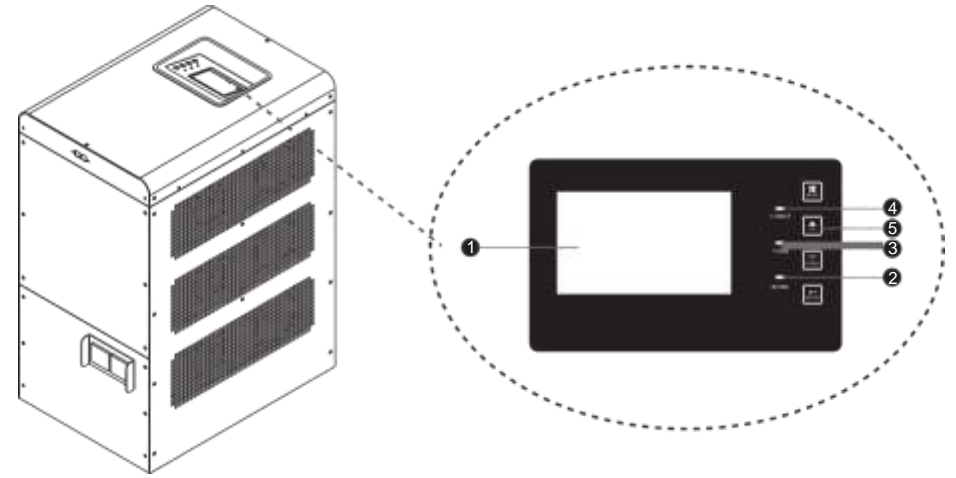

- 1. LCD display
- 2. Status indicator
- 3. Charging indicator
- 4. Fault indicator
- 5. Function buttons
- 6. Grid breaker
- 7. Load
- 8. Grid
- 9. PV input
- 10. Battery input
- 11. AC output breaker
- 12. CAN&RS485 communication port
- 13. BTS
- 14. Grounding

## Packing List

Before installation, please inspect the unit. Be sure that nothing inside the package is damaged. You should have received the following items inside of package:

- |   |                         |
|---|-------------------------|
| The unit x1                                     | User manual x1          |
| communication cable(RJ45 to DB9) x1             | BTS cable x1            |
| Software CD x1                                  | Fixing screws(M8*15) x4 |
| communication cable(USB to RS485 ) x1(Optional) |                         |



## User Environment

- Put the apparatus on level floor and lock cartwheel.
- On both side of the equipment more than 50cm from walls or other obstructions, to facilitate heat dissipation
- Do not put the inverter on flammable construction materials. The inverter cannot be used in metal dust environment.
- Avoid direct sunlight, rain, or use of this equipment in damp conditions
- The inverter cannot be used in Corrosive materials, salt and combustible gas.

## Battery Connection

**CAUTION:** For safety operation and regulation compliance, it's requested to install a separate DC over-current protector or disconnect device between battery and inverter. It may not be requested to have a disconnect device in some applications, however, it's still requested to have over-current protection installed. Please refer to typical amperage in below table as required fuse or breaker size.

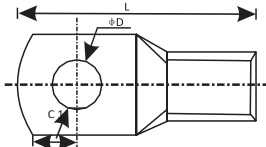

**WARNING!** All wiring must be performed by a qualified personnel. **WARNING!** It's very important for system safety and efficient operation to use appropriate cable for battery connection. To reduce risk of injury, please use the proper recommended cable and terminal size as below.

**NOTE1:** Please only use sealed lead acid battery, Lithium battery. Please check maximum charging voltage and current when first using this inverter.

**NOTE2:** Please use 60VDC/300A circuit breaker.

**NOTE3:** The over voltage category of the battery input is II.

Please follow below steps to implement battery connection:

Step 1: Check the nominal voltage of batteries. The nominal input voltage for inverter is 48VDC. Remove the battery cable locking bar.

Step 2: User battery cable remove insulation sleeve 10 mm to crimping terminal and heat shrinkable sleeve(25mm).

Step 3: Insert the ring terminal of battery from underneath to battery connector of inverter and make the bolts(M8\*15) are tightened with torque 2~3Nm.

Make sure polarity at both the battery and the energy storage inverter is correctly connected and ring terminals are tightly screwed to the battery terminals and screw up the battery cable locking bar.

**WARNING!** Wrong connections will damage the unit permanently.

Table 3 Charge Mode Specifications

Grid Charging Mode		
INVERTER MODEL	9KW	12KW
Per Phase	60A	80A
Absorption Voltage	Pb	50.0V
	Li	52.8V
Refloat Voltage	Pb	54.8V
	Li	53.6V
Float Voltage	Pb	57.2V
	Li	54.0V

Solar Charging Mode		
INVERTER MODEL	9KW	12KW
Rated Power	3*3KW	3*3KW
Efficiency	98.0% max 145Vdc	
Max.PV Array Open Circuit Voltage	145Vdc	
PV Array MPPT Voltage Range	34Vdc-130Vdc	
Min Battery Voltage For PV Charge	+/-0.3%	
Battery Voltage Accuracy	+/-2V	
PV Voltage Accuracy		
Charging Algorithm	Pb:3-Step;Li:4-Step	
Temperature Compensation Coefficient	-3mv/°C/cell(25°C ref)	
Charging algorithm for lead acid battery		
Charging algorithm for Lithium battery		

Table 2 Inverter Mode Specifications

INVERTER MODEL	9KW	12KW
Rated output power	9000W	12000W
Output Voltage Waveform	Pure Sine Wave	
Output Voltage Regulation	230Vac±1%	
Output Frequency	60Hz or 50Hz	
Peak Efficiency	≥93%	
Overload Protection	immediately @Short circuit; 10 seconds@load > 150%; 30 seconds@125% < load < 150%; 60 seconds@110% < load < 125%; 30 minutes@100% < load < 110%	
Surge Capacity	2* rated power for 5 seconds	
Nominal DC Input Voltage	48Vdc	
Cold Start Voltage	46.0Vdc	
Low DC Warning Voltage @ load < 20%	44.0Vdc	
@ 20% ≤ load < 50%	42.8Vdc	
@ load ≥ 50%	40.4Vdc	
Low DC Warning Return Voltage @ load < 20%	46.0Vdc	
@ 20% ≤ load < 50%	44.8Vdc	
@ load ≥ 50%	42.4Vdc	
Low DC Cut-off Voltage @ load < 20%	42.0Vdc	
@ 20% ≤ load < 50%	40.8Vdc	
@ load ≥ 50%	38.4Vdc	
High DC Recovery Voltage	58Vdc	
High DC Cut-off Voltage	60Vdc	
Rated output current per phase	13A	17.4A
Dynamic response speed (0 ~ 100%)	20ms	
Rate of wave distortion (THD) (Linearity loads)	Off grid ≤ 2%; Grid discharge ≤ 3%; Grid charge ≤ 3%	
Power factor	Grid discharge 99.9% & Grid charge 99.9%	
No-load	70W	120W

Recommended battery cable and terminal size:

Mode	Typical Amperage	Battery Capacity	Wire Size	Ring Terminal		Torque Value
				Cable (mm <sup>2</sup> )	Dimensions D(mm) L(mm)	
9KW	180A	400AH	2*3AWG	54	8.4 35	2~3Nm
			3*4AWG	63		
12KW	240A	600AH	2*2AWG	67	8.4 39	2~3Nm
			3*3AWG	80		

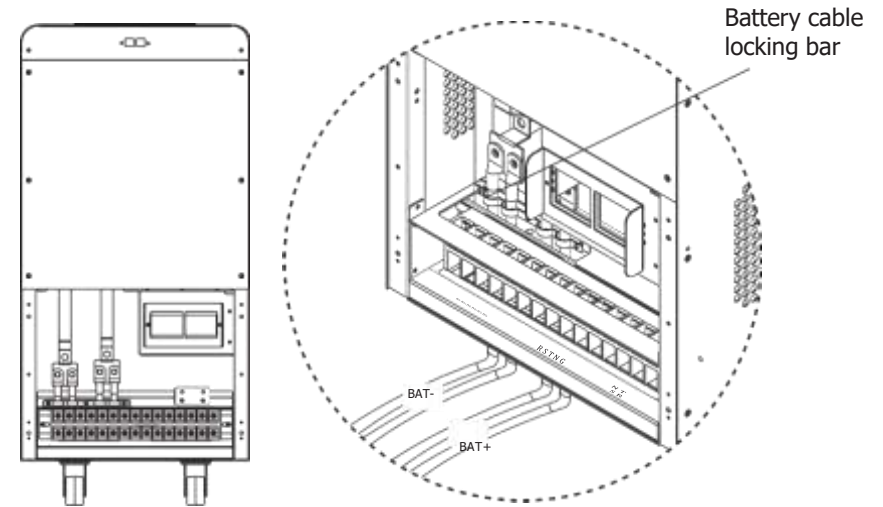

**WARNING: Shock Hazard**  
Installation must be performed with care due to high battery voltage in series.

**CAUTION!!** Do not place anything between the flat part of the inverter terminal and the ring terminal. Otherwise, overheating may occur.  
**CAUTION!!** Do not apply anti-oxidant substance on the terminals before terminals are connected tightly.  
**CAUTION!!** Before making the final DC connection or closing DC breaker/disconnector, be sure positive (+) must be connected to positive (+) and negative (-) must be connected to negative (-).



## PV Connection

**Notice:** This inverter three independence PV chargers(PV1,PV2,PV3),you can only connect one solar panel or connect two solar panel or connect three solar panel all.

**CAUTION:** Before connecting to PV modules, please install separately a DC circuit breaker between inverter and PV modules.

**WARNING!** All wiring must be performed by a qualified personnel

**WARNING!** It's Very important for system safety and efficient operation to use appropriate cable for PV module connection. To reduce rise of injury, please use the proper recommended cable size an blow.

Suggested user 1\*6AWG(13.3MM<sup>2</sup>) cable for PV wires and Torque 2~2.5Nm.

### PV Module Selection:

When selecting proper PV modules, please be sure to consider below parameters:

1. Open circuit Voltage(Voc) of PV modules not exceeds max. PV array open circuit voltage of inverter.
2. Open circuit Voltage(Voc) of PV modules should be higher than min. Battery voltage.

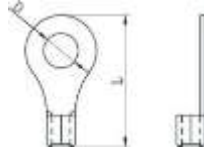

Solar Charger Mode	
INVERTER MODEL	9KW/12KW
Max. PV Array Open Circuit Voltage	145Vdc
PV Array MPPT Voltage Range	64Vdc~130Vdc
Min. Battery Voltage for PV charge	34Vdc

### Please follow below steps to implement battery connection:

Step 1: Remove insulation sleeve 8 mm and insert conductor into cable ring terminal.

Step 2: Check correct polarity of connection cable from solar panel and PV input connectors. after that, connect the one solar panel positive to PV1+, negative to PV1-; connect the second solar panel positive to PV2+, negative to PV2-; connect the thirdly solar panel positive to PV3+, negative to PV3-.

Step 3: Make sure the wires are right and securely connected.

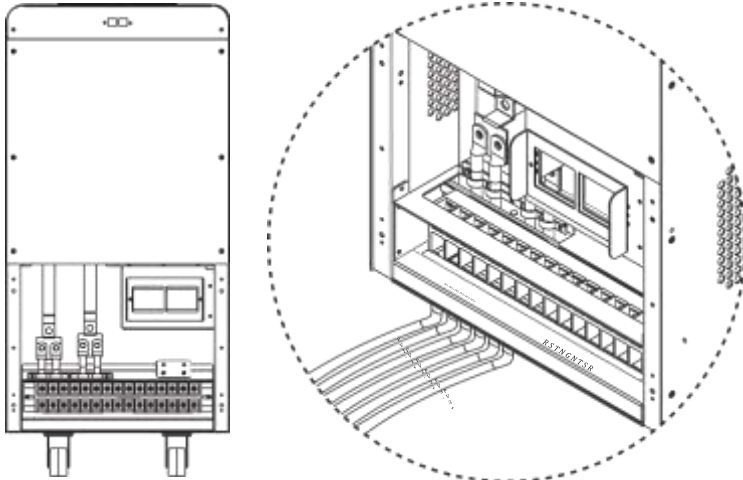

## SPECIFICATIONS

Table 1 Line Mode Specifications

INVERTER MODEL	9KW	12KW
Input Voltage Waveform	Sinusoidal( grid or generator)	
Nominal Input Voltage	120Vac or 230Vac	
Low Loss Voltage	65Vac±7V or 174Vac±7V(SLO); 95Vac±7V or 174Vac±7V(FST); 95Vac±7V or 187Vac±7V(APL)	
Low Loss Return Voltage	70Vac±7V or 184Vac±7V(SLO); 100Vac±7V or 184Vac±7V(FST); 100Vac±7V or 196Vac±7V(APL)	
High Loss Voltage	140Vac±7V or 272Vac±7V(SLO,FST); 140Vac±7V or 253Vac±7V(APL)	
High Loss Return Voltage	135Vac±7V or 265Vac±7V(SLO,FST); 135Vac±7V or 250Vac±7V(APL)	
Max AC Input Voltage	150Vac or 300Vac	
Nominal Input Frequency	50Hz / 60Hz	
Low Loss Frequency	40±1Hz(SLO or FST)/47.5±0.05Hz(APL)	
Low Loss Return Frequency	42±1Hz(SLO or FST)/47.5±0.05Hz(APL)	
High Loss Frequency	65±1Hz(SLO or FST)/51.5±0.05Hz(APL)	
High Loss Return Frequency	63±1Hz(SLO or FST)/50.05±0.01Hz(APL)	
Output Short Circuit Protection	Line mode:Circuit Breaker Battery mode:Electronic Circuits	
Transfer Time	<20ms	
Output power derating:	<p>When AC input voltage drops to 120V or 230V depending on models,the output power will be derated</p> <p>120Vac model:</p> <p>230vac model:</p>	

87	Power feedback protection	
88	Firmware version inconsistent	
89	Current sharing fault	
90	CAN ID setting Error	



**Power Inverter**  
Líderes en transformaciones de energía

## GRID/AC OUTPUT Connection

### Preparation

**CAUTION!!** Before connection to Grid, please install a separate AC breaker between inverter and Grid. This will ensure the inverter can be securely disconnected during maintenance and fully protected from over current of Grid. The recommended spec of AC breaker is 63A/400V.

**CAUTION!!** There are two terminal blocks with "AC OUTPUT" and "Grid" markings. Please do NOT-misconnect load and grid connectors.

**WARNING!** It's very important for system safety and efficient operation to use appropriate cable for AC connection. To reduce risk of injury, please use the proper recommended cable terminal size as below.

Mode 9KW/12W	Wire Size	Ring Terminal			Torque Value
		Cable (mm <sup>2</sup> )	Dimensions		
			D(mm)	L(mm)	
AC Output	10~8 AWG	5.3~8.4	6.3	25	2~2.5Nm
Grid	8-6 AWG	8.4~13.3	6.3	29	2~2.5Nm

### Please follow below steps to implement battery connection:

- Step 1: Before make AC OUTPUT/Grid connection, be sure to open battery DC protector and AC breaker between inverter and Grid.
- Step 2: Remove insulation sleeve 8 mm for conductors and crimping terminal and heat shrinkable sleeve(25mm).
- Step 3: connect the Grid phase R(U),S(V),T(W) ,N wires to Grid-R,-S, -T,-N of inverter silk-screen respectively. tighten the terminal screws.
- Step 4: then, connect the Load R(U),S(V),T(W) ,N wires to AC OUTPUT-R,-S,-T,-N of inverter silk-screen respectively. tighten the terminal screws.
- Step 5: Make sure the wires are securely connected.

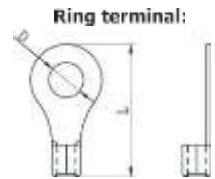

### CAUTION: Important

Be sure to connect AC with correct polarity. If L and N wires are connected reversely, it may cause grid short-circuited when these inverters are worked in parallel operation. If Grid phase R,S and T wires are connected reversely, it may be caused inverter connect fail.

**CAUTION:** Appliances such as air conditioner are required at least 2~3 minutes to restart because it's required to have enough time to balance refrigerant gas inside of circuits. If a power shortage occurs and recovers in a short time, it will cause damage to your connected appliances. To prevent this kind of damage, please check manufacturer of air conditioner if it's equipped with time-delay function before installation. Otherwise, this energy storage inverter will trig overload fault and cut off output to protect your appliance but sometime it still causes internal damage to the air conditioner.

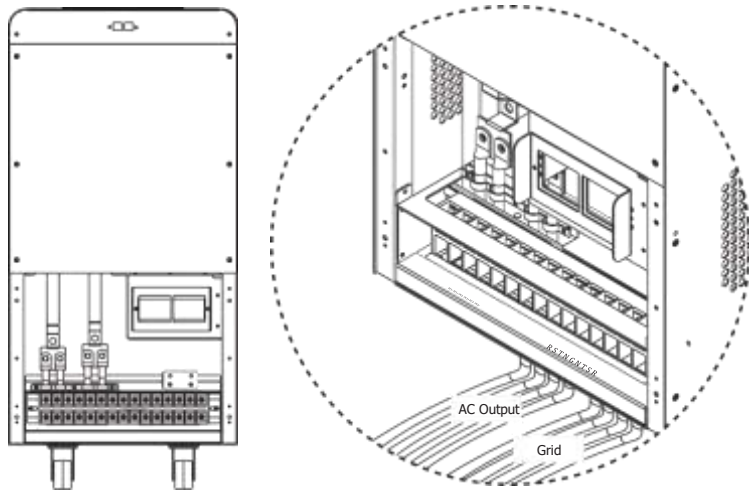

### Connecting To The GROUND





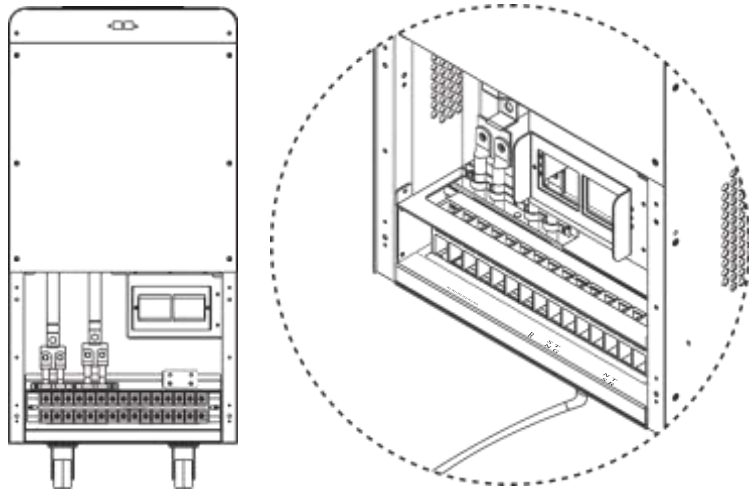
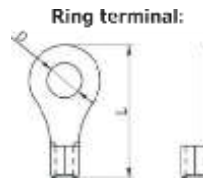











For safe operation, please use one more wire with ring terminal to connect grounding.

Wire Size	Ring Terminal		Torque Value
	Cable (mm <sup>2</sup> )	Dimensions D(mm) L(mm)	
8AWG	10	6.3 25	2~2.5Nm



### WARNING INDICATOR

Warning Code	Warning Event	Icon flashing
61	Fan is locked when inverter is on.	[61] ⚠
62	Fan2 is locked when inverter is on.	[62] ⚠
63	Battery is over-charged.	[63] ⚠
64	Low battery	[64] ⚠
	Overload	
67		[67] ⚠ ⚡
70	Output power derating	[70] ⚠
72	Solar charger stops due to low battery.	[72] ⚠
73	Solar charger stops due to high PV voltage.	[73] ⚠
74	Solar charger stops due to over load.	[74] ⚠
75	Solar charger over temperature	[75] ⚠
76	PV charger communication error	[76] ⚠
77	Parameter error	[77] ⚠
80	CAN fault	[80] ⚠
81	Host loss	[81] ⚠
82	Synchronization loss	[82] ⚠
83	Battery voltage detected different	[83] ⚠
84	AC input voltage and frequency detected different	[84] ⚠
85	AC output current unbalance	[85] ⚠
86	AC output mode setting is different	[86] ⚠

26	Inverter grid over current error	[26] 
27	Inverter radiator over temperature	[27] 
31	Solar charger battery voltage class error	[31] 
32	Solar charger current sensor error	[32] 
33	Solar charger current is uncontrollable	[33] 
41	Inverter grid voltage is low	[41] 
42	Inverter grid voltage is high	[42] 
43	Inverter grid under frequency	[43] 
44	Inverter grid over frequency	[44] 
51	Inverter over current protection error	[51] 
52	Inverter bus voltage is too low	[52] 
53	Inverter soft start failed	[53] 
55	Over DC voltage in AC output	[55] 
56	Battery connection is open	[56] 
57	Inverter control current sensor error	[57] 
58	Inverter output voltage is too low	[58] 

## Communication And BTS Connection

### Communication connection

Please use supplied communication cable to connect to inverter and PC. Insert bundled CD into a computer and follow on-screen instruction to install the monitoring software. For the detailed software operation, please check user manual of software inside of CD. You should use RJ45 cable as follows.

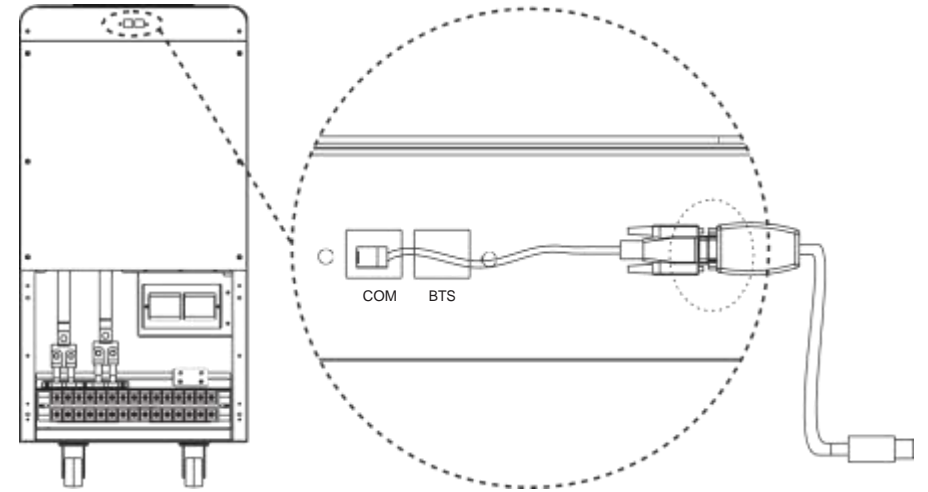

### BTS connection

An optional battery Remote Temperature Sensor(BTS) is recommended for accurate battery recharging. The controller will not perform temperature compensation for charging parameters if the BTS is not used. You should use the RJ11 cables to connect Negative Temperature Coefficient(NTC), as follows:

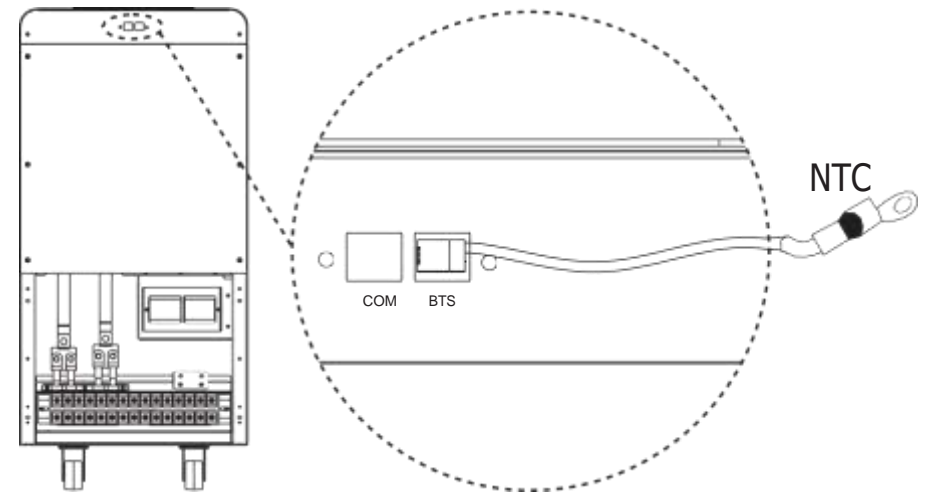

## OPERATION AND DISPLAY PANEL

The operation and display panel, shown in below chart, is on the front panel of the inverter. It includes three indicators, four function keys and a LCD display, indicating the operating status and input/output power information.



### LED Indicator

LED Indicator		Messages	
AC/ INV		Solid On	Output is powered by Grid in Line mode.
		Flashing	Output is powered by battery or PV in battery mode
● CHG	Yellow	Flashing	Battery is charging /or discharging.
▲ FAULT	Red	Solid On	Fault occurs in the inverter.
		Flashing	Warning condition occurs in the inverter.

### Function Keys

Function key	Description.
MENU	Enter or exit setting mode go to previous selection.
UP	Increase the setting data.
DOWN	Decrease the setting data.
ENTER	Confirm the selection in setting mode or go to next selection.







stop state	The inverter stop working if you turn off the inverter by the soft key or error has occurred in the condition of no grid.	
------------	---	--

### Fault Reference Code

Fault Code	Fault Cause	LCD Indication
01	Fan is locked when inverter is off	
02	Inverter transformer over temperature	
03	battery voltage is too high	
04	battery voltage is too low	
05	Output short circuited	
06	Inverter output voltage is high	
07	Overload time out	
08	Inverter bus voltage is too high	
09	Bus soft start failed	
11	Main relay failed	
21	Inverter output voltage sensor error	
22	Inverter grid voltage sensor error	
23	Inverter output current sensor error	
24	Inverter grid current sensor error	
25	Inverter load current sensor error	

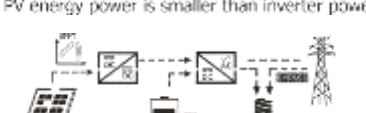

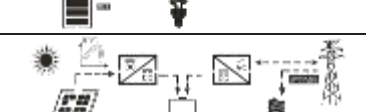

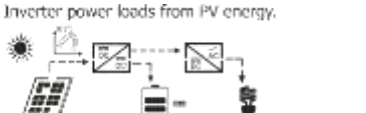
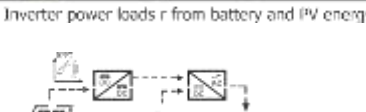
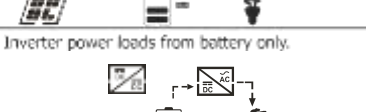
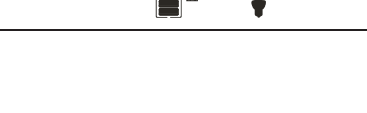

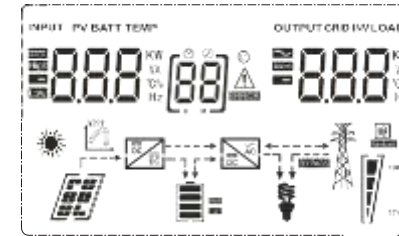

## Operating State Description

Operation state	Description	LCD display
Sell state Note: The system generates electricity when it has sufficient sunshine supplying power to your home and sending any excess power back to the grid.	PV energy is sold back to grid.	PV energy power is larger than inverter power 
		PV energy power is smaller than inverter power 
Match load state Note: DC power produced from your solar array is converted by the inverter into AC power, which is then sent to your main electrical panel to be used by your household appliances. Any excess power generated is not sold back to the grid, but stored in battery.	PV energy is charging into the battery or converted by the inverter to the AC load.	PV energy power is larger than inverter power 
		PV energy power is smaller than inverter power 
		PV is off 
Charge state	PV energy and grid can charge batteries. 	
Bypass state	Errors are caused by inside circuit error or external reasons such as over temperature, output short circuited and so on. 	
Off Grid state	The inverter will provide output power from battery and PV power.	Inverter power loads from PV energy. 
		Inverter power loads r from battery and PV energy. 
		Inverter power loads from battery only. 
		

## LCD Display Icons



Icon	Function description	
<b>Input Source Information and Output Information</b>		
	Indicates the AC information	
	Indicates the DC information	
	Indicate input voltage, input frequency, PV voltage, battery voltage and charger current. Indicate output voltage, output frequency, load in VA, load in Watt and discharging current.	
<b>Configuration Program and Fault Information</b>		
	Indicates the setting programs.	
	Indicates the warning and fault codes. Warning: flashing with warning code. Fault: lighting with fault code.	
<b>Battery Information</b>		
	Indicates battery level by 0-24%, 25-49%, 50-74% and 75-100% in battery mode and charging status in line mode.	
In AC mode, it will present battery charging status.		
Status	Battery voltage	LCD Display
Constant Current mode / Constant Voltage mode	<2V/cell	4 bars will flash in turns.
	2 ~ 2.083V/cell	Bottom bar will be on and the other three bars will flash in turns.
	2.083 ~ 2.167V/cell	Bottom two bars will be on and the other two bars will flash in turns.
Floating mode. Batteries are fully charged.	> 2.167 V/cell	Bottom three bars will be on and the top bar will flash.
		4 bars will be on.

In battery mode, it will present battery capacity.		
Load Percentage	Battery Voltage	LCD Display
	< 1.717V/cell	
	< 1.817V/cell	
	> 1.983	
	< 1.867V/cell	
	> 2.033	

**Load Information**

				75%~100%

**Mode Operation Information**

	Indicates unit connects to the PV panel.
<b>BYPASS</b>	Indicates load is supplied by grid power.
	Indicates the solar charger circuit is working.

**Mute Operation**

--	--

**Support three-phase equipment**

Step 1: Check the following requirements before commissioning:

- Correct wire connection
- Ensure all breakers in Line wires of load side are open and each Neutral wires of each unit are connected together.

Step 2: Turn on all units sequentially

LCD display in L1-phase unit	LCD display in L2-phase unit	LCD display in L3-phase unit

Step 3: Switch on all AC breakers of Line wires in grid. If grid is detected and three phases are matched with unit setting, they will work normally. Otherwise, the AC icon will flash and they will not work in line mode.

LCD display in L1-phase unit	LCD display in L2-phase unit	LCD display in L3-phase unit

Step 4: If there is no more fault alarm, the system to support 3-phase equipment is completely installed.

Step 5: Please switch on all breakers of Line wires in load side. This system will start to provide power to the load.

**Note 1:**To avoid overload occurring, before turning on breakers in load side, it's better to have whole system in operation first.

**Note 2:** Transfer time for this operation exists. Power interruption may happen to critical devices, which cannot bear transfer time.



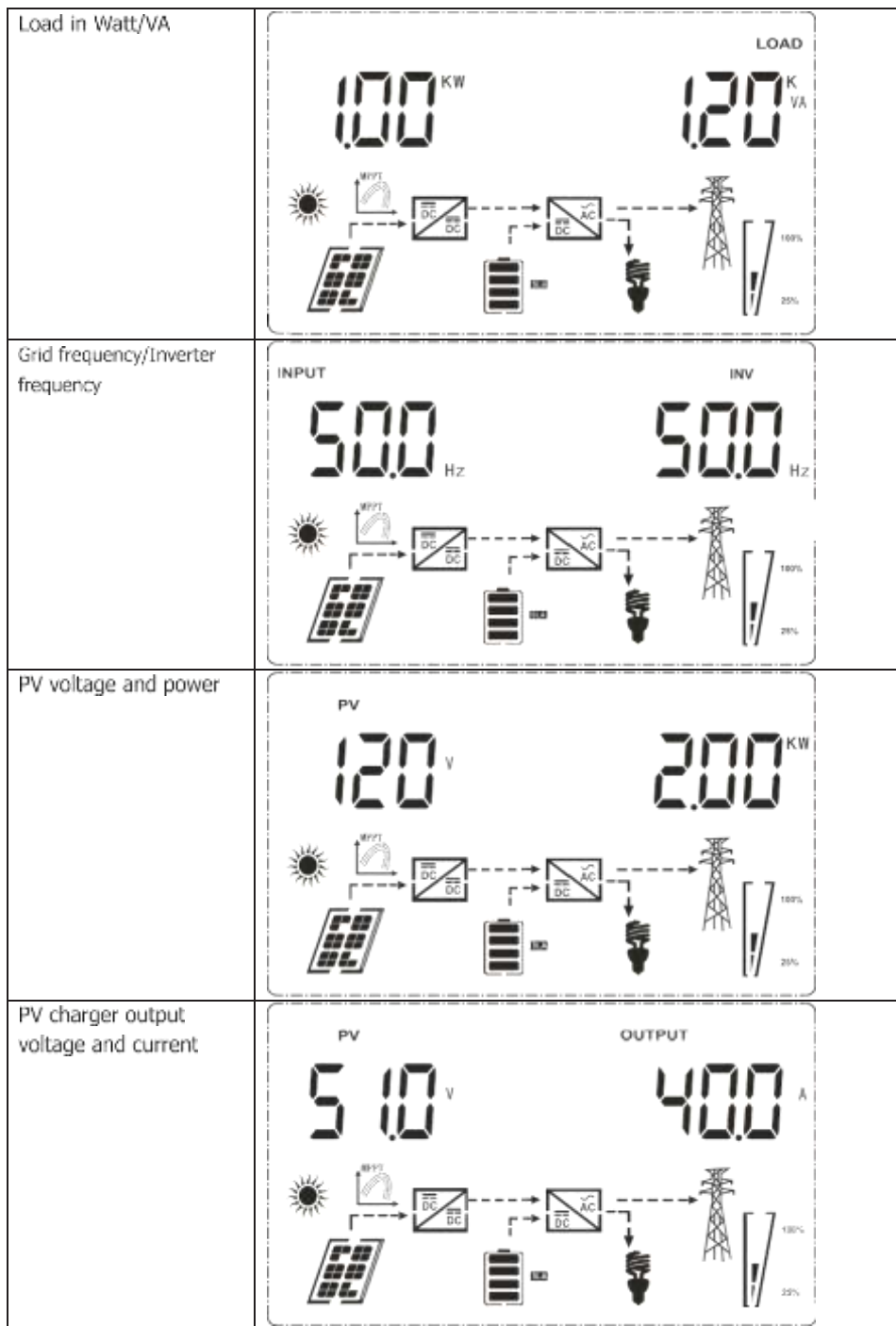

### LCD Setting

After pressing and holding MENU button for 2 seconds, the unit will enter setting mode. Press "UP" or "DOWN" button to select setting programs. And then, press "ENTER" or "MUNE" button to confirm the selection and exit.

#### Setting Programs:

Program	Selectable option	Description
	[5] INV	Select the setting of inverter.
	[5] CHA	Select the setting of solar charger.
	[5] 545	Select the setting of the system.
Power use mode	[0] PL	Load priority mode larger higher
	[0] FL	FL: the energy will never sell to the grid and the solar energy will fully supply to the load.
	[0] FS	FS: the solar energy will Sell to the grid ignore the load.
	[0] UPS	UPS: the converter will charger the battery to full voltage Combine with the Solar Charge Controller.
	[0] P <sub>0</sub>	PO: the inverter will turn to off grid state when the solar energy is enough.
Maximum charging current(DC)	[02] 120	To configure total charging current for solar and grid (Max. charging current = grid charging current + solar charging current)
Maximum Grid charging current(DC)	[03] 60	
Maximum discharging current (AC)	[04] 130	Maximum Discharging current: To configure Max Discharging current when the inverter is on Grid-tie mode.



AC input voltage range	Narrow [09] FSt	If selected, acceptable AC input voltage range will be within 184-272 VAC.
	Wide [09] SLo	If selected, acceptable AC input voltage range will be within 105-272 VAC.
	APP-VDE4105 [09] APPL	If selected, acceptable AC input voltage range will conform to VDE4105.
Power saving(Search) mode enable/disable	Saving mode disable(default) [08] SdS	If disabled, no matter connect load is low or high, the on/off status of inverter output will not be effected.
	Saving mode enable [08] SEEn	If enable, the inverter begins search mode if the AC load connected is pretty low or not detected. The inverter's "search" mode reduces stand-by energy consumption during no-load conditions.
Setting the min voltage point	[07] 48.0	PL: when the battery voltage is lower than the setting point, the inverter will start to recharge the battery.
		FL: when the battery voltage is lower than the setting point, the inverter will start to recharge the battery.
		FS: when the battery voltage is lower than the setting point, the inverter will start to recharge the battery.
		<b>UPS: no use.</b>
		PO: when the battery voltage is lower than the setting point, the inverter will start to recharge the battery.
Setting the balance voltage point	[08] 50.0	PL: when the battery voltage is higher than the setting point, the inverter will supply the power match the load, don't sell power back to grid. When the battery voltage is lower than the setting point, the inverter will stop discharging from battery.
		FL: when the battery voltage is higher than the setting point, the inverter will supply the power match the load, don't sell power back to grid. When the battery voltage is lower than the setting point, the inverter will stop discharging from battery.

## Display Setting

The LCD display information will be switched in turns by pressing "UP" or "DOWN" key. The selectable information is switched as below order: battery voltage, battery current, inverter voltage, inverter current, grid voltage, grid current, load in Watt, load in VA, grid frequency, inverter frequency, PV voltage, MPPT charging power, MPPT charging output voltage, MPPT charging current. Choose the L1,L2,L3 phase unity by pressing "Enter" key

Selectable information	LCD display
Battery voltage/Battery current	<p>The LCD display shows 'BATT' at the top. On the left, '52.0' is displayed with a 'V' symbol. On the right, '58' is displayed with an 'A' symbol. Below the numbers is a schematic diagram of the power system: a solar panel (with 'MPPT' label) and a battery (with 'BMS' label) are connected to a DC-DC converter (labeled 'DC DC'). This is connected to an inverter (labeled 'DC AC'), which is connected to a light bulb (load) and a power grid (tower). A battery level indicator on the right shows 100% and 20% marks.</p>
Inverter output voltage/Inverter output current	<p>The LCD display shows 'INV' at the top. On the left, '229' is displayed with a 'V' symbol. On the right, '13.0' is displayed with an 'A' symbol. Below the numbers is the same schematic diagram as in the first row.</p>
Grid voltage/Grid current	<p>The LCD display shows 'GRID' at the top. On the left, '229' is displayed with a 'V' symbol. On the right, '8.0' is displayed with an 'A' symbol. Below the numbers is the same schematic diagram as in the first row.</p>

Auto turn page	[64] PLE	If selected, the display screen will auto turn the display page.
	[64] PLd	If selected, the display screen will stay at latest screen until user turns keys on.
Backlight control	[67] LON	Backlight on.(default)
	[67] LOF	Backlight off.
Record Fault code	[68] FdS	disable
	[68] FEN	Record enable.

\* 09 > 08 > 07 max voltage > balance voltage point > the min voltage point.

\* 11 > 10 DC recovery voltage > low DC cut-off voltage.

\* 46 > 45 > 44 solar changer float voltage solar changer refloat voltage > solar changer absorb voltage.



		FS: when the battery voltage is higher than the setting point, the inverter will discharging with max current. When the battery voltage is lower than the setting point, the inverter will stop discharge from battery. UPS: when the battery voltage is lower than the setting point, the inverter will start to recharge the battery. PO: When the battery voltage is lower than the grid
Setting the max voltage point	[09] 52.0 <sub>v</sub>	PL: In this mode, when the battery voltage is higher than the setting point, the inverter will sell power to the grid. When the battery voltage falls to the setting voltage below, the inverter will discharge match the load. FL: In this mode when the battery voltage is higher than the setting point, the inverter will discharge match the load. start selling UPS: In this mode when the battery voltage is higher than the setting point, the inverter will stop charging to battery. PO: When the battery voltage is higher than the setting point, the inverter will back to the off grid state.
low DC cut-off voltage	[10] 40.0 <sub>v</sub>	48V model default setting: 42.0V Setting range is from 40.0V to 48.0V. Increment of each click is 0.1V. Low DC cut-off voltage will be fixed to setting value no matter what percentage of load is connected.
low DC recovery voltage	[11] 44.0	If the inverter is in the low voltage fault state of the battery, the battery voltage higher than the voltage, inverter will remove the battery low voltage fault.
High DC cut-off voltage	[12] 60.0 <sub>v</sub>	48V model default setting: 60.0V Setting range is from 58.0V to 60.0V. Increment of each click is 0.1V. High DC cut-off voltage will be fixed to setting value no matter what percentage of load is connected.
Off-Grid enable	On(default) [13] ON	Turn on the inverter output when the grid is off.
	Off [13] OFF	Shut down the inverter output when the grid is off.

Grid-use enable/disable	Grid-use enable [14] UEN	Enable the inverter to connect to an AC input source.
	Grid-use disable [14] Uds	Disable the inverter to connect to an AC input source.
Low battery voltage Protection mode	[15] UAL	If "Usually-Defined" is selected, low DC cut-off voltage can be referred to of the page 28 in this manual.
	User-Definac [15] USE	If "User-Defined" is selected, low DC cut-off voltage by 8 of the page 16 in this manual.
Output voltage	[16] 230 <sup>v</sup>	Set the output voltage amplitude.
Output frequency	[17] 50.0 <sup>Hz</sup>	50Hz.(default)
	[17] 60.0 <sup>Hz</sup>	60Hz.
Grid charge enable	[18] UCE	Enable grid charge.(default)
	[18] UCd	Disable grid charge.
Solar Charger working Switch	[41] ON	Open or close the Solar Charge Controller output
	[41] OFF	
Battery type	[42] Pb	Select the battery type.(Lead acid or Lithium)
	[42] L	
Battery AH	[43] 200	Set the AH of the battery.

Solar Charger absorb voltage	[44] 50.0 <sup>v</sup>	Set the Absorb voltage.(Refer to the Charging Curve)
Solar Charger refloat voltage	[45] 54.8 <sup>v</sup>	Set the Refloat voltage.(Refer to the Charging Curve)
Solar Charger Float voltage	[46] 57.2 <sup>v</sup>	Set the Float voltage.(Refer to the Charging Curve)
Solar Charger max current	[47] 60.0 <sup>A</sup>	Set the max output current of the Solar Charge Controller.(Refer to the Charging Curve)
Solar Charger absorb current	[48] 10.0 <sup>A</sup>	Set the absorb current of the Solar Charge Controller.(Refer to the Charging Curve)
Solar Charger low DC cut-off voltage	[49] 34.0 <sup>v</sup>	If the battery voltage is lower than the set point, the Solar Charge Controller will close the output.
Solar Charger high DC cut-off voltage	[50] 60.0 <sup>v</sup>	If the battery voltage is higher than the set point, the Solar Charge Controller will close the output.
Auto restart when overload occurs	[61] L-E	Restart enable.(default)
	[61] L-d	Restart disable.
Auto restart when over temperature occurs	[62] L-E	Restart enable.(default)
	[62] L-d	Restart disable.
Overload bypass: When enabled, the unit will transfer to line mode if overload occurs in battery mode	[63] bYE	Bypass enable.(default)
	[63] bYd	Bypass disable.